



48V 15Ah Lithium-Ion Battery Datasheet

Premium Lithium-Ion Battery for Light Electric Scooters.

Contents

1. Technical Specifications	3
1. Battery Pack Specifications:	3
2. BMS Specification.....	4
2. Mechanical Drawing and Casing Design	5
1. Mechanical Drawing of Battery Pack Assembly	5
2. Battery Pack Casing Design & External Views.....	5
3. Mobile Application.....	6
4. Connection Port & Interface Command.....	6
5. Applications.....	6
6. Charger Specification	7
7. Compliance & Certification	7
1. Electrical Safety and Abuse Resistance	7
2. Environmental and Mechanical Robustness.....	7
3. Functional System Performance	7
4. Operational Reliability and Readiness	7
8. Warranty Terms, Conditions & Support.....	8
1. Warranty Coverage	8
2. Conditions for Validity.....	8
3. Exclusions and Limitations	8

1. Technical Specifications

1. Battery Pack Specifications:

The following table provides a detailed technical specification:

Battery Pack General Specifications	
Model	EVR048015
Battery Type	Sinopoly SP-NCM-3Ah
Nominal Voltage	48V
Voltage Range	36 ~ 54.6V
Nominal Capacity	15Ah
Nominal Energy Capacity	720 Wh
Cycle Life	After 1000 Cycles the capacity will be higher than 70% of the initial capacity at 0.5C charge and 1C discharging.
Electrical Specifications	
Rated Voltage/Cell	3.6 V
Voltage Range per Cell	3V – 4.2V
Charge Voltage Max	54.6V
Charge Current Max	0.5 C (7A)
Discharge Voltage Min	36V
Continuous Discharge Current	2C (30A)
Recommended Discharge Current	1C
Recommended Discharge Power	720 W
Mechanical Specifications	
Casing	Metal with sealing
Package Weight	~ 4.25 kg
Dimensions (mm)	~ 260 x 72 x 130 mm

2. BMS Specification

The following table provides a detailed technical specification:

Battery Management System (BMS) Specifications	
Model	EVR13S48V
Over charge detection voltage	4.25V ± 0.04V
Over charge release voltage	4.05V ± 0.05V
Over discharge detection voltage	2.7V ± 0.1V
Over discharge release voltage	3V ± 0.1V
Discharge Overcurrent Protection	25A ± 2A
Short circuit detection delay	256µs
Charge balance start voltage	4.1V
Balance current	40mA
Environmental Conditions	
Operating Temperature	-20°C ~ 80°C
Charging Temperature Range	0 – 55°C
Discharging Temperature Range	-20 – 55°C
Humidity	10% – 90%
Cooling Method	Natural Cooling and Heat Sink
Ingress Protection	IP21
Built-in Protections	
Overcharge protection	Available
Over-discharge protection	Available
Overcurrent and short circuit protection	Available
Temperature-based charge/discharge protection	Available
Cell Balancing Capability (Keep Voltages Uniform Across Cells)	Available

2. Mechanical Drawing and Casing Design

1. Mechanical Drawing of Battery Pack Assembly

The Mechanical drawing shows the overall dimensions and external layout of the battery pack.

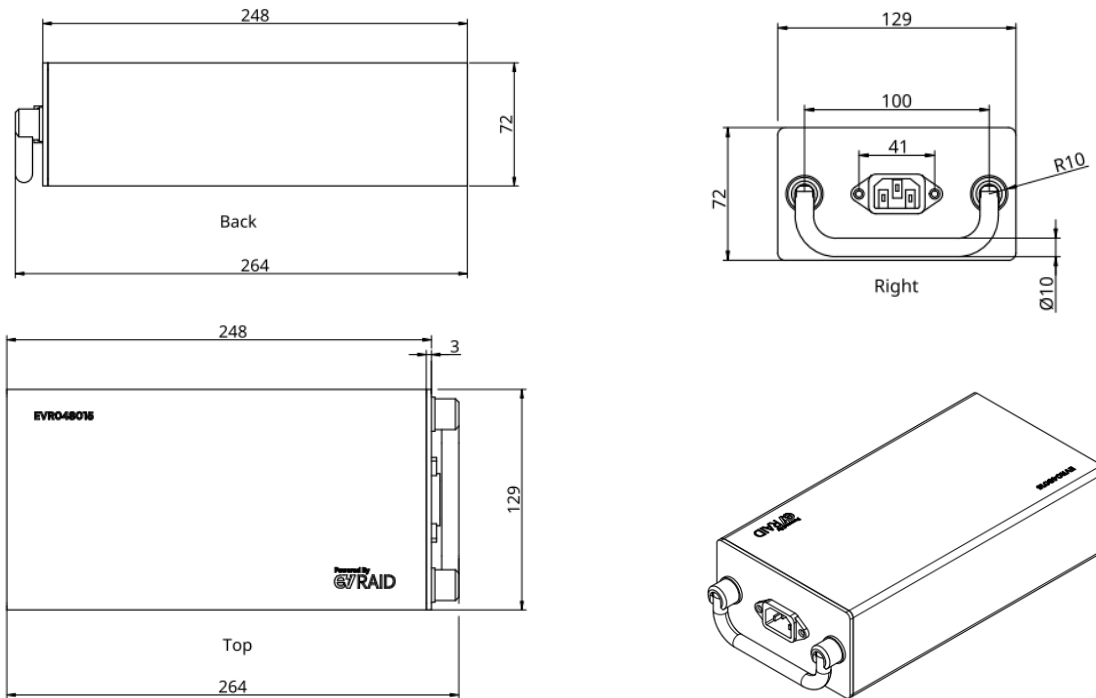

2. Battery Pack Casing Design & External Views

The render images illustrate the mechanical design, casing structure.



3. Mobile Application



AVAILABLE NOW
EVRAID: Battery Monitor

- Connect via smartphone
- Monitor battery

SCAN QR CODE TO DOWNLOAD ON



Bluetooth 5.0 is compatible with the EVRAID iOS/Android Battery Monitor App for tracking voltage, temperature, current, and individual cell health.

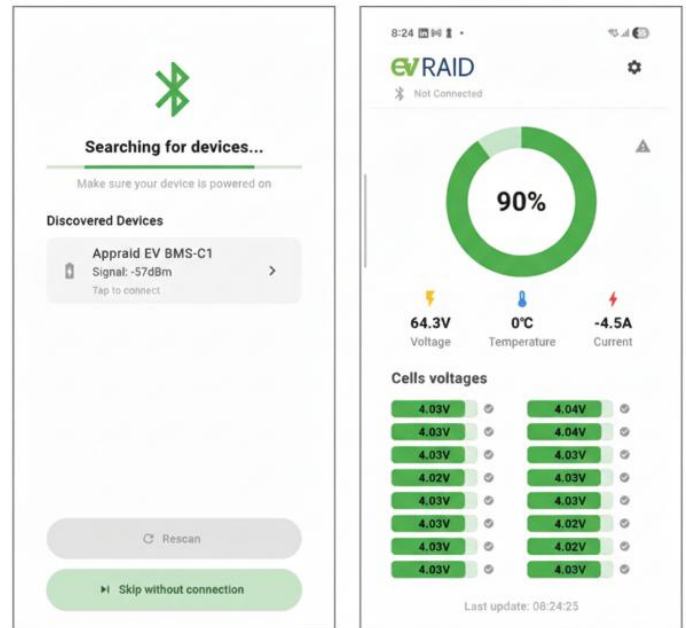

4. Connection Port & Interface Command

Item	SPEC	Interface	Refer
CHARGE	IEC 60320 C13 (Male)	Red	
DISCHARGE	JST RCY Male	Yellow	

5. Applications



eMobility

Bikes, scooters, wheel-chairs, and more.



Energy Storage

Residential, commercial, off-grid backup systems, and more.



Portable Power

Power tools, outdoor applications, and more.

6. Charger Specification

The battery pack is delivered without an external charger.

When using a charger, the nominal charging voltage should be 54.6V and up to 3A (the product without charger)

7. Compliance & Certification

All battery packs offered in this quotation are designed, manufactured, and tested in compliance with relevant international standards to ensure **performance, safety, and reliability** in line with their intended application. The following standards and certifications apply:

1. Electrical Safety and Abuse Resistance

- **Electrical Safety & Abuse Evaluation** (safe and stable battery behavior under normal and abnormal electrical operating conditions).
- **Charge & Discharge Performance** (reliable performance during charging, discharging, and stress scenarios).

2. Environmental and Mechanical Robustness

- **Resistance Validation** (vibration, shock, temperature variation, and humidity).
- **Operational Durability Assessment** (confirmation of durability during handling, transportation, and real-world operation).

3. Functional System Performance

- **System-Level Integration Validation** (ensure reliable interaction with the vehicle platform).
- **Lifecycle Performance Verification** (predictable and stable operation across the intended lifecycle)

4. Operational Reliability and Readiness

- **Long-Term Stability Testing** (confirm long-term stability and performance consistency).
- **Operational Robustness Assurance** (dependability for daily operational use).

8. Warranty Terms, Conditions & Support

We are pleased to offer high-quality Lithium battery systems, engineered to deliver superior performance and reliability for light EV applications. The following terms and conditions govern the warranty coverage applicable to the battery units supplied under this quotation.

1. Warranty Coverage

The battery is covered by a limited warranty for a period of **6 Months** from the date of purchase.

This warranty covers:

- Defects in materials and workmanship under normal and proper usage conditions.
- Abnormal capacity loss is not attributable to natural degradation due to aging or cycling, provided the battery is within the specified operating limits.
- The integrated **Battery Management System (BMS)**, including the embedded communication module, against defects affecting normal operation, communication stability, or controller interaction under approved conditions.

2. Conditions for Validity

The warranty shall remain valid only if the following conditions are met:

- Installation and operation must be carried out by qualified personnel in accordance with the manufacturer's specifications and safety guidelines.
 - The battery must be used strictly within its designed parameters, including:
 - Operating voltage, current, and charge/discharge cycles
 - Recommended Depth of Discharge (not exceeding 80%)
- Ambient temperature range of 0°C to 55°C (charging) and –20°C to 60°C (discharging)
- The battery must be charged at least once every **six (6) months** during periods of non-use or storage to prevent cell degradation.

3. Exclusions and Limitations

This warranty **does not cover** failures, defects, or damage resulting from any of the following:

- Improper or unauthorized **installation**, misuse, or modification of the battery or its components.
- Physical **damage** caused by impact, fire, water submersion, corrosion, or exposure to harsh environmental conditions.
- Incorrect cabling, reversed polarity, or the use of incompatible chargers or systems.
- Operation outside of approved electrical configurations, such as unsupported series or parallel connections.
- Tampering with the battery management system (BMS), serial labels, or casing.